

The Digital Twin of an Industrial Production Line Within the Industry 4.0 Concept

Ján Vachálek, Lukáš Bartalský, Oliver Rovný,
Dana Šišmišová

Institute of Automation, Measurement and Applied
Informatics, Faculty of Mechanical Engineering, Slovak
University of Technology in Bratislava
Nám. slobody 17, 812 31 Bratislava, Slovak Republic
jan.vachalek@stuba.sk

Martin Morháč, Milan Lokšík

SOVA Digital, a.s., Bojnická 3, 831 04
Bratislava, Slovak Republic
martin.morhac@sova.sk

Abstract—This article presents the digital twin concept, which is an augmented manufacturing project created in close collaboration by SOVA Digital and the Institute of Automation, Measurement and Applied Informatics (ÚAMAI), of the Faculty of Mechanical Engineering, Slovak University of Technology in Bratislava with the support of SIEMENS. The project is a technological concept focusing on the continuous optimization of production processes, proactive maintenance, and continuous processing of process data. This project is the basis for further work to promote the concept of Industry 4.0. for the needs of the industry subjects within Slovakia. Its basic goal is to support the existing production structures within the automotive industry and the most efficient use of resources by augmented production and planning strategies, such as the digital twin presented here.

Keywords— *digital twin, optimization of production, genetic algorithm, data collection*

INTRODUCTION

Presently we stand on the threshold of a technical revolution that will fundamentally change the way we live, work and communicate with each other. By the current rate, scope and complexity; this transformation will be as fundamental for humanity as any other technological paradigm change from the past. Nobody knows how technology will develop in the future, but one thing is clear: the response to these changes must be integrated on a global basis from public to private sectors, including academia and commercial users. We may rightfully call the fourth industrial revolution as a digital one; merging technologies that blur the boundaries between the physical, digital and biological spheres.

The rate the current discoveries has no historical precedent. In comparison with the previous industrial revolutions, the fourth is developed by more of an exponential rate than linear; affecting almost every industry in the countries around the world. The breadth and the depth of these changes foreshadow the transformation of entire current production systems and their management. The possibilities granted by a billion people connected by mobile devices having unprecedented computing power, data storage and

networking is, truly astounding. These possibilities are compounded by the emergent technical breakthroughs in the areas such as artificial intelligence, robotics, the internet of things, autonomous vehicles, 3D printing, nanotechnologies, biotechnologies, materials science, and the future of quantum computing.

One of the technological concepts of the aforementioned industrial revolution is the concept of the digital twin (DT). A DT is essentially a functional system of continuous process optimization, which is formed by the cooperation of physical production lines with a digital “copy” [1, 2, 3, 4]. It creates the digital factory environment, in which the company can optimize the operation directly through the production chain, manipulate parameters and production processes; adapting the product to market requirements. The data created during this time paints a comprehensive picture of a given product and the production process. A digital twin collects and evaluates the information continuously, allowing, among other things, to shorten and streamline the production cycle, reduce the rise time of introducing new products, detecting inefficient settings of the underlying processes. The concept of the digital twin, therefore, is built on the principle known today as Industry 4.0.

I. THE DIGITAL TWIN PROJECT – PHYSICAL PRODUCTION

The project of the digital twin was originated in the Institute of Automation, Measurement and Applied Informatics of the Faculty of Mechanical Engineering of the Slovak University of Technology in Bratislava. The digital twin is formed by the physical production line and its digital “copy”. The major feature of this arrangement is the interface, through which data exchange takes place.

For creating the simulated production part, we have employed didactic stations made by FESTO. These are illustrated in Fig. 1-4. The production chain simulated the manufacturing of pneumatic cylinders and it begins by the station link. This part represents the process of the physical

production itself. The stations were ranked in order: the tray, the manipulator, the test of the workpiece height, the process station (the gravity conveyor, the drilling and the control of the hole after the drilling), the manipulator, the sorting station (4 conveyor belts). The last workstation was the manual assembly, where the individual components were combined (the piston, the spring, the cylinder body and the lid) and packed together with the product information. The simulated manufacturing line produced three kinds of cylinders, one cylinder with metal body and two cylinders with a plastic body. There were differences in the size of the drilled hole between the types of pistons. For their better recognition, the bodies of the pneumatic cylinders are color-coded. The individual components of the pneumatic cylinders are shown in Fig. 5.



Fig. 1. The workpieces tray and the manipulator



Fig. 2. The control of the height and the process station

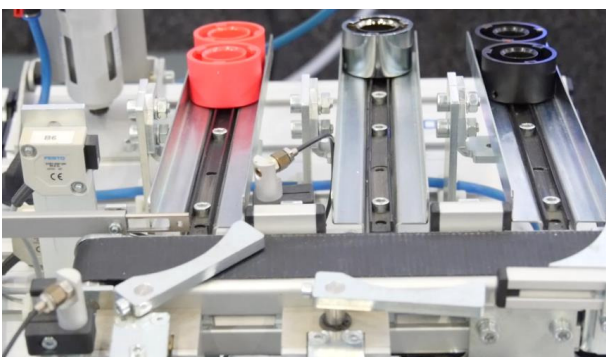

Fig. 3. The sorting belts



Fig. 4. The assembling workstation



Fig. 5. The components of the pneumatic cylinders

II. THE DIGITAL TWIN PROJECT – THE DIGITAL PRODUCTION LINE

The digital part is based on the simulation tool called Plant Simulation (PS) made by SIEMENS. The digital simulation model of the production line was created in this environment. This model was a detailed virtual copy of the physical process involved in assembling the hydraulic pistons. The scheme of the real workstation along with the model in PS is shown in Fig. 6.

The output from the physical process was to transfer the information about the movement times of a particular component to data storage. In our case, we used the OPC data server by SIEMENS to process information transfer.

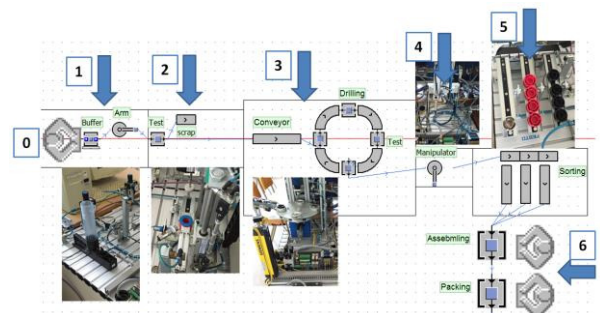

Fig. 6. The scheme of the processes

Every process was mapped in detail, so that the Digital twin (DT) could correctly interpret the collected data. For example,

at the beginning of the project, some timestamps of the processes were shifted to software from experimental observation. After a brief introduction to the hardware particulars in the previous section, now we will move to the definition of the digital equivalent.

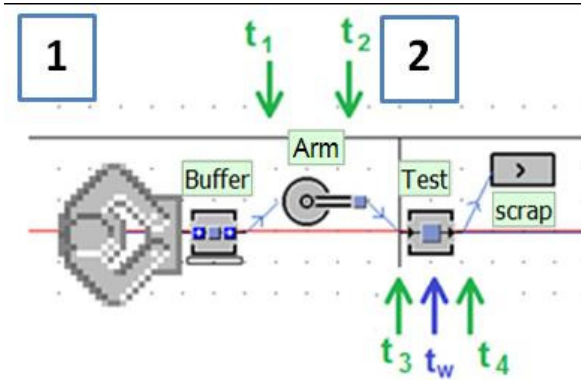

Fig. 7. The process No. 1 and No. 2

The description of the processes is shown in Fig. 7. The first process is the operator, which supplies the line. The operator puts the components to the system (the tray) according to the production plan. The second process is the arm, which is taken from the tray. The arm (manipulator) timestamps were sent to the DT. ((t_1) the arm will assume the component, (t_2) the arm will forward the component). Then the DT can set its running the value to the manipulation process duration.

Within the frame of the second process is also the test, which evaluates the measurement of the component size. The input time on the test (t_3) is not identical with the output time (t_2), because the timestamp is created only after the arm is in the position one (in the space of the tray). The test station will start to work right at that moment with a 2 s difference. The time t_w is the working time of the testing and it was to be changed according to the type of the manufactured product. The time t_4 represents the timestamp of the product leaving from the test.

This way, all processes can be eventually mapped, in order to avoid an incorrect interpretation of data transfer. Subsequently, the transferred data was used to set the correct values in the simulation model.

III. THE DIGITAL TWIN PROJECT – OPTIMIZATION

Many experiments can be created on the simulated plant, even without a direct connection with the physical production line. Is possible to answer questions, for example; what will happen in the overall production line when a certain parameter is changed. In other words, the model allows one to modify production parameters, then to monitor the behavior of the system without the risk of financial loss in the real production line. If we connect the simulation model to the real system, this opens up yet other possibilities to optimize the production system. The resulting DT is shown in Fig. 8.

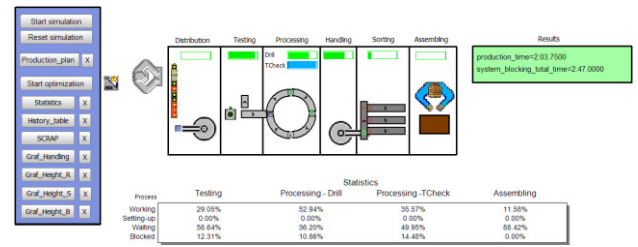

Fig. 8. The digital twin shown in Plant Simulation (PS)

The first major advantage of this process is that the DT collects and evaluates the actual production process. It ensures parameter topicality in simulation, but it also gives the possibility to intervene in case the process does not work according to expectation. For example, one of the tests was to keep the manipulator at its working position, by manually restraining it. The DT immediately noted, that the process does not work in the given cycle time (Fig. 9). In case that this situation persists, the DT could warn the operator about it in time and give sufficient instructions to mend the issue.

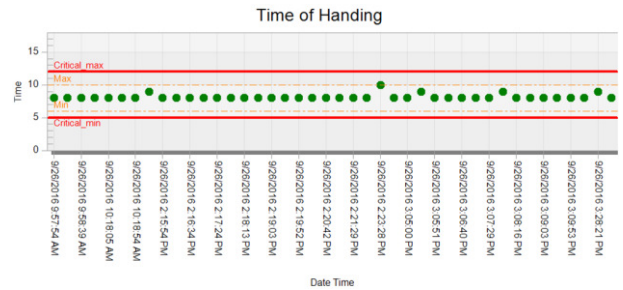

Fig. 9. The monitoring of the manipulator time cycle and the monitoring of the production transfer time next to the process (Time of Handling)

We used the digital twin for the optimization of the production according to the production plan. We designed the production plan in a way that it triggered physical and virtual production as well. In effect, the timing of the real and simulated system was different by a mere 1 second.

The production was optimized by a genetic algorithm, which adjusted the simulation model, then simulated the DT within the frame of the PS environment [5, 6]. It was necessary to define the objective function and constraints to use this genetic algorithm. For our model, the overall objective function is complex. Therefore, the algorithm is defined as a combination of various objective functions describing sub-goals in the production. These include the requirement for the lowest cost of all products, and are related to minimizing production time of each product series as well. In our case, the minimization parameter was the total production time of our product as is shown in Fig. 10. Because there are several objective functions, it was necessary to determine their weight.

The constraint in the algorithm represents the number of working stations that are available for the particular product to execute the particular operation. Each product has a number of constraints in accordance to the following relations

$$\begin{aligned}
& (P_1 \times K_{11} \times M_{K_{11}} \times K_{P_1}) + (P_1 \times K_{21} \times M_{K_{21}} \times K_{P_1}) + \dots + \\
& \quad (P_1 \times K_{m1} \times M_{K_{m1}} \times K_{P_1}) \\
& \quad \text{for product } P_1 \\
& (P_2 \times K_{12} \times M_{K_{12}} \times K_{P_2}) + (P_2 \times K_{22} \times M_{K_{22}} \times K_{P_2}) + \dots + \\
& \quad (P_2 \times K_{m2} \times M_{K_{m2}} \times K_{P_2}) \\
& \quad \text{for product } P_2 \\
& (P_n \times K_{1n} \times M_{K_{1n}} \times K_{P_n}) + (P_n \times K_{2n} \times M_{K_{2n}} \times K_{P_n}) + \dots + \\
& \quad (P_n \times K_{mn} \times M_{K_{mn}} \times K_{P_n}) \\
& \quad \text{for product } P_n
\end{aligned} \tag{1}$$

where:

P_n - type of product (numerical value 1),
 K_{mn} - m-th type of operation for n-th type of product (numerical value 1),
 $M_{K_{mn}}$ - number of working stations needed for making the m-th type of operation for n-th type of product,
 K_{Pn} - quantity of product.

Using this, a particular constraint can be defined as

$$M_{K_{mn}-min} > P_n \times K_{mn} \times M_{K_{mn}} < M_{K_{mn}-max}. \tag{2}$$

With the constraints and the objective function in place, one must also define the size and the number of generations and the number of observations per individual. The generation represents a number of solutions that the algorithm combines, and the observation represents a number of simulations for each new generated individual [6]. Thus, the total number of simulations are given by:

$$\text{Size of generation} \times (2 \times \text{Number of generations} - 1) \times \text{Observations per individual}. \tag{3}$$

In our case, we chose for the following parameters:

Size of generation = 50,
Number of generations = 5,
Observations per individual = 1.

With using the settings introduced above for the genetic algorithm, we have been looking for the optimum sequence of operations in the production plan (Fig. 10 and Fig. 11). The ultimate minimization parameter was the total production time. This was first performed on the basis of the digital twin, then we repeated the experiment with the real system, resulting a total reduction in production time by 5.2%.

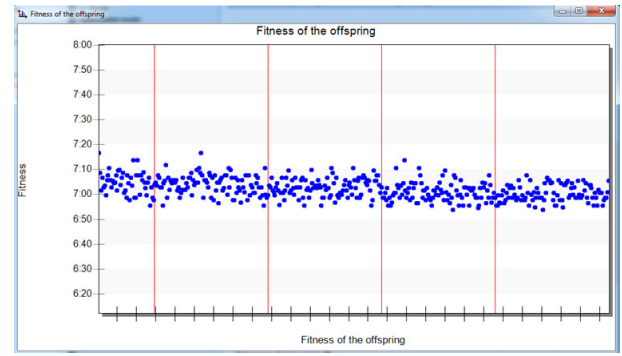

Fig. 10. The x-axis represents the quantity of experiments and the y-axis represents achieved production time

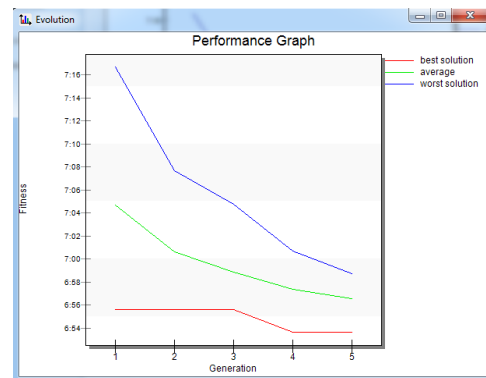

Fig. 11. The results achieved in the individual absorptions (generations)

The method describe above ensures the ability to adapt flexibly to changes in the product assortment and increases production turnout. The digital twin can adjusted to the requirements needed for various production areas, including predictive maintenance or the optimization to minimize resources (tools, people, energy, etc.).

IV. CONCLUSION (3)

The digital twin concept demonstrated the interaction of the real production processes with a digital simulation model. This model was a detailed virtual copy of all processes in the mock-up of the production line, including material flow. The interaction of the manufacturing facilities and the simulation model may bring new insight into the dynamics of the production process. The analyses that were performed on the created cyber-physical system (the physical devices connected to the digital twin) contributed to a better understanding of the inherent link between digital technologies and the real hardware.

Currently, we are working on the next development version of the concept described in this paper that we refer to as DT 2.0. Further work will include the implementation of yet more advanced optimization techniques within the Industry 4.0 concept, and our own version of a genetic algorithm that may

be integrated in the PS software environment. This shall offer better options for setting of the input parameters and the output parameters of the production process. Furthermore, proactive maintenance and modern sensors to monitor a large number of parameters is necessary to provide an increased digital overview for later “Big data” analysis [7, 8].

The main point of Industry 4.0 is increasing operational efficiency in manufacturing. This, of course, follows from the principle of digitization and the availability of continual data flow, along with novel concepts to link the preparatory production stage with real production. It can be logically expected that new production and logistics management strategies will follow from this gradual shift in technology.

ACKNOWLEDGMENT

We would like to express our thanks to the companies SOVA Digital and SIEMENS Slovakia, without whose cooperation this project would not be realized. We are grateful for the financial support provided by the grant provided through the projects KEGA 014STU-4/2015 and 027STU-4/2017 and VEGA 1/0604/15 and 1/0317/17. We appreciate the support of the VW foundation given through the project called “To develop by the technique”.

REFERENCES

- [1] M. Morháč, “Digitálne dvojčá ako jeden zo základných konceptov Industry 4.0”, *Automotive Engineering Journal*, 01/2016, pp. 22-23, Česká republika
- [2] M. Morháč, “Na začiatku bude treba poupratovať – Uplatnenie priemyslu 4.0”, *TREND 02/2016 príloha Priemysel 4.0 a Slovensko*, pp. 61, Slovensko
- [3] Sova Digital, “Industry 4.0. “ Online., 2016. [cit. 31. 12. 2016] Dostupné na Internete: <http://www.industry4.sk>
- [4] V. Vasek, P. Dostalek, J. Dolinay, D. Janacova, K. Kolomazník, “Microcontrollers and Modern Control Methods.” In *Proceedings of the 2nd WSEAS International Conference on Computer Engineering and Applications*. Mexico: WSEAS Press [IT], 2008, s. 195-198. ISBN 978-960-6766-33-6.
- [5] D. Pirovic, M. Gudlin, P. Cosic, “Implementation of Genetic Algorithm as the Part of Discrete Simulation in Production Planning,” *1st Regional Conference - Mechatronics in Practice and Education MECH - CONF 2011*
- [6] Tecnomatix Siemens, “Tecnomatix Plant Simulation User Guide” 2016, 2016.
- [7] J. Vachálek, O. Smutný, “Software implementations of data warehousing for on-line identification of real systems. “In: *Strojné inžinierstvo 2002 „Mechanical engineering 2002“: Zborník abstraktov a príspevkov 6. medzinárodnej vedeckej konferencie*. - Bratislava: STU v Bratislave, 2002. - ISBN 80-227-1783-5.
- [8] J. Vachálek, Ján “Practical experiments with data warehousing based identification of linear systems.” In: *Information Technologies & Control: Proceedings of the 4th International PhD. Workshop*. - Praha: ÚTIA AV ČR, 2003. - ISBN 80-239-1333-6.